



CARITAS UNIVERSITY AMORJI-NIKE, EMENE, ENUGU STATE

Caritas Journal of Engineering Technology

CJET, Volume 5, Issue 1 (2026)

Article History: Received: 21st Feb., 2026 Revised: 20th April, 2026 Accepted: 3rd May 2026

Enhancing Data Transmission In a Wireless Communication Network Using Fuzzy Based Smartcity Technique

¹Ibeaha, D. C.,
²Chukwuagu, M.I.
 Ochiagha, G.C ³

¹Products Development Institute (PRODA) Enugu

^{2,3}Department Electrical/Electronic Engineering

Caritas University Amorij-Nike, Emene, Enugu State

Corresponding authors: dcibeaha.id@gmail.com; chukwuaguifeanyi35@gmail.com

Abstract

The rapid evolution of wireless communication networks within the framework of smart cities has necessitated the development of intelligent solutions to overcome data transmission challenges, such as latency, interference, signal degradation, and unreliable bandwidth allocation. This study presents a fuzzy-based Smart City technique aimed at enhancing data transmission efficiency and reliability in wireless communication networks. The proposed approach integrates fuzzy logic controllers to dynamically manage communication parameters, including signal strength, network congestion, and channel availability, enabling adaptive transmission strategies in real-time. By incorporating context-aware data prioritization and intelligent routing decisions, the fuzzy-based system ensures optimal data flow, particularly in densely populated urban environments with high device connectivity. Simulation results demonstrate significant improvements in throughput, reduced packet loss, and lower transmission delays when compared to conventional techniques. This research highlights the potential of fuzzy logic in addressing complex, nonlinear issues in smart city wireless infrastructure, paving the way for more resilient and responsive communication networks. The results obtained were the conventional bandwidth that caused poor data transmission in a wireless communication network was 0.7 Mbps. On the other hand, when FUZZY based smart city technique was integrated into the system, it instantly increased to 1 Mbps and the conventional multipath fading that caused poor data transmission in a wireless communication network was 1.3 μ s. Meanwhile, when FUZZY based smart city technique was imbibed into the system, it simultaneously reduced to 1 μ s.. Finally, with these results obtained, it definitely meant that the percentage enhancement in the data transmission in a wireless communication network when FUZZY based smart city technique was incorporated in the system was 30%.

Keyword: *Wireless, Transmission line, communication, Fuzzy, Smartcity*

1.0 INTRODUCTION

The increasing demand for real-time data communication and ubiquitous connectivity in smart city environments has placed immense pressure on wireless communication networks. Smart cities, characterized by the integration of advanced technologies to manage urban infrastructure, services, and resources, rely heavily on efficient wireless communication systems to function optimally (Zanella et al., 2014). However, challenges such as network congestion, signal interference, bandwidth limitations, and dynamic user mobility often degrade data transmission quality, leading to reduced performance and user dissatisfaction (Akyildiz et al., 2006).

Traditional wireless communication techniques often lack the flexibility and adaptability required to cope with the dynamic and heterogeneous nature of smart city environments. These methods typically depend on fixed algorithms and rigid control parameters that may not be efficient in real-time urban scenarios with high traffic variability (Gubbi et al., 2013). To address these limitations, intelligent techniques such as fuzzy logic have been introduced into the wireless communication domain. Fuzzy logic offers a powerful approach for managing uncertainties and nonlinearities in complex systems. It enables the design of adaptive control systems that can make decisions based on imprecise or incomplete data, making it ideal for managing data transmission in unpredictable smart city environments (Zadeh, 1996). When integrated into wireless networks, fuzzy-based techniques can dynamically adjust key transmission parameters such as signal strength, interference thresholds, and channel access priorities to optimize performance. Recent research has shown the potential of fuzzy logic in improving the reliability and efficiency of wireless communication systems through intelligent decision-making and adaptive resource allocation (Yadav & Singh, 2019). By applying fuzzy-based techniques within a smart city context, it is possible to enhance the robustness of data transmission, reduce latency, and improve the overall quality of service. This study, therefore, focuses on the enhancement of data transmission in wireless communication networks using a fuzzy-based Smart City technique, aiming to address existing inefficiencies and support the growing communication needs of modern urban infrastructures.

2.0 METHODOLOGY

1. To characterize and establish the causes of poor data transmission in a wireless communication network

Table 1 characterized and established causes of poor data transmission in a wireless communication network

S/N	Cause of Poor Data Transmission	Parameter	Threshold Value (S.I Unit)	Conventional causes of poor data transmission in a wireless communication network	Description / Effect
1	Low Signal Strength	Received Signal Strength (RSS)	< -85 dBm (decibel-milliwatts)	-88 dBm	Causes frequent disconnection, high error rates.
2	High Interference	Signal-to-Interference Ratio (SIR)	< 20 dB	17 Db	Reduces signal clarity; leads to data packet loss.
3	High Noise Level	Signal-to-Noise Ratio (SNR)	< 15 dB	12 Db	Causes corruption of transmitted data.
4	Bandwidth Limitations	Bandwidth	< 1 Mbps (Megabits per second)	0.7 Mbps	Insufficient for modern applications like video streaming or VoIP.
5	Excessive Network Latency	Latency	> 100 ms (milliseconds)	104 ms	Leads to delays in communication and poor user

					experience.
6	Packet Loss	Packet Loss Rate	> 1%	4%	Causes data retransmission, reducing overall throughput.
7	Jitter (Variation in Packet Arrival Time)	Jitter	> 30 ms	33 ms	Causes choppy audio and video in real-time applications.
8	Obstructions (Physical Barriers)	Signal Attenuation	> 20 dB over 10 m	23 Db	Concrete walls, metal structures reduce signal power and reliability.
9	Overloaded Access Points / Network Congestion	User Density per AP	> 30 users/AP	34 users/AP	Too many users cause competition for bandwidth and slow data rate.
10	Outdated or Incompatible Devices	Device Data Rate Capability	< IEEE 802.11n standard (< 150 Mbps)	147 Mbps	Limits throughput; cannot handle modern traffic efficiently.
11	Multipath Fading	Delay Spread	> 1 μ s (microsecond)	1.3 μ s	Causes signal distortion due to multiple signal paths.
12	Improper Antenna Configuration	Antenna Gain	< 3 dBi	2.3 dBi	Reduces transmission range and signal quality.

Notes:

- These values vary slightly depending on specific deployment environments and technology standards (e.g., 4G, 5G, Wi-Fi 6).
- Persistent violations of these thresholds usually necessitate hardware upgrades, network reconfiguration, or advanced error correction techniques.

To design a conventional SIMULINK model for data transmission in a wireless communication network

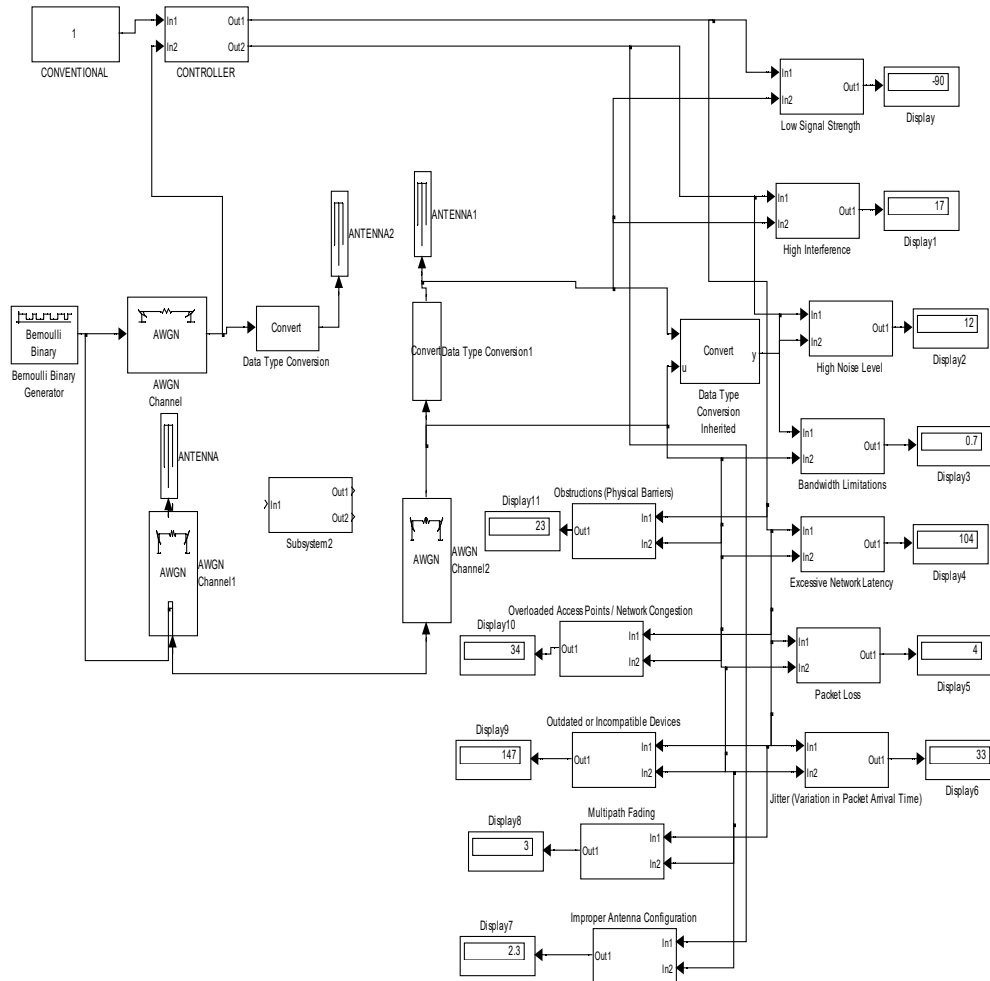

Fig 1 designed conventional SIMULINK model for data transmission in a wireless communication network

The results obtained were as shown in figures 8 and 9

To develop a smart city rule base that will minimize the causes of poor data transmission in a wireless communication network

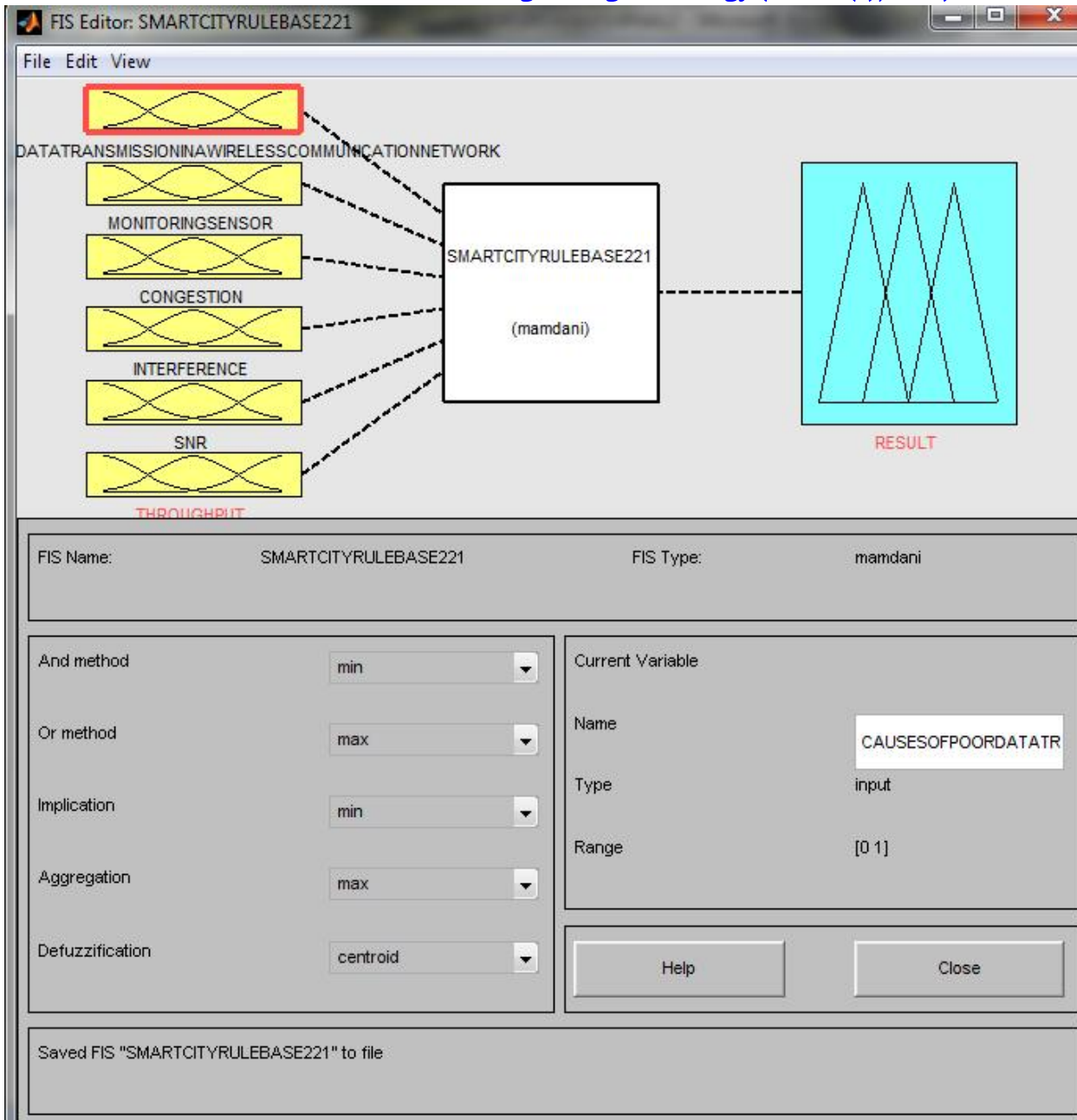

Fig 2 developed smart city fuzzy inference system that will minimize the causes of poor data transmission in a wireless communication network

This had six input of causes of poor data transmission in a wireless communication network, monitoring sensor, Congestion, interference, SNR and throughput.

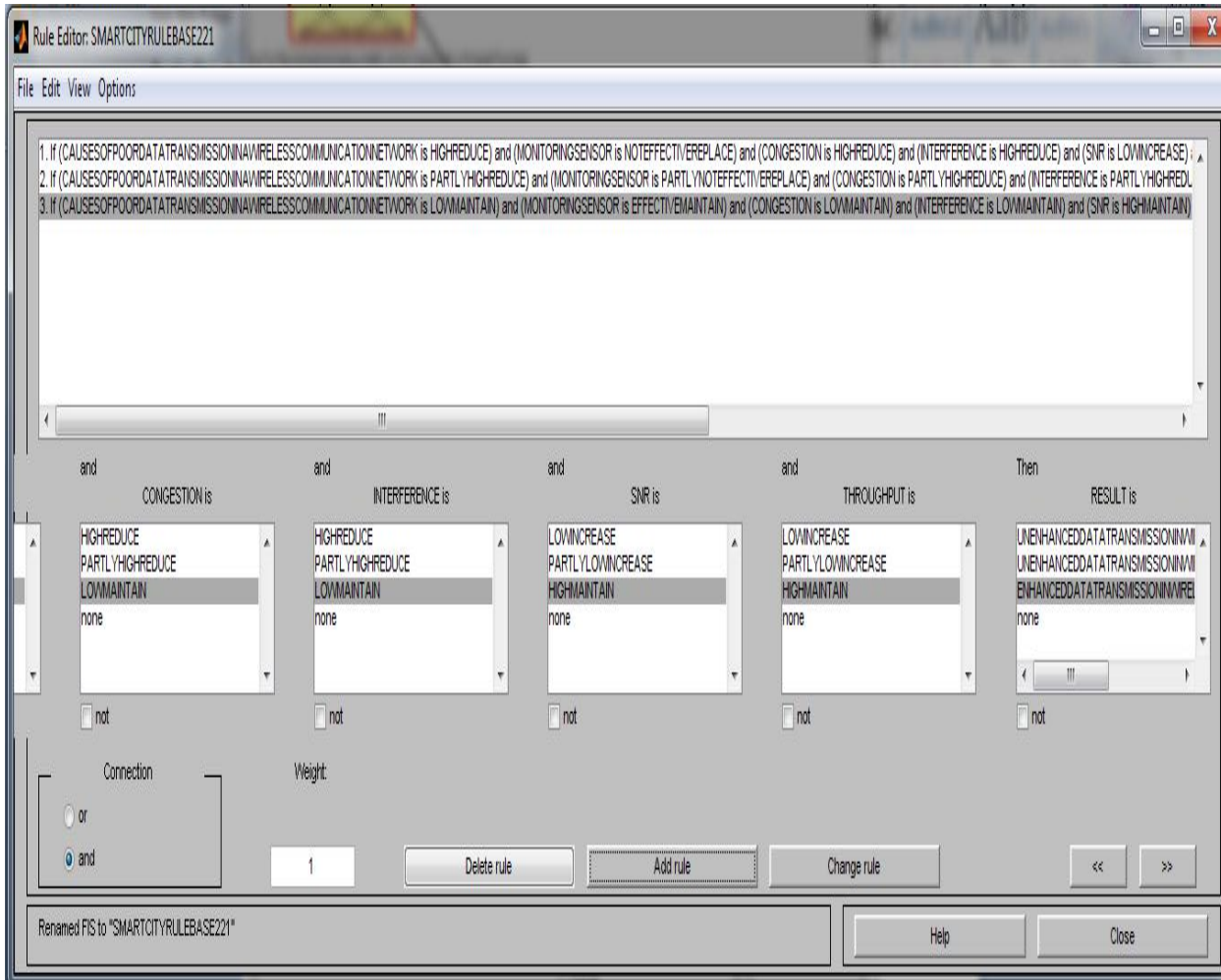

Fig 3 developed smart city rule base that will minimize the causes of poor data transmission in a wireless communication network

The detailed rules were as shown in table 2

Table 2 detailed developed smart city fuzzy inference system that will minimize the causes of poor data transmission in a wireless communication network

1	If causes of poor data transmission in a wireless communication network is high reduce	And monitoring sensor is not effective replace	And Congestion is high reduce	And interference is high reduce	And SNR is low increase	And throughput is low increase	Then result is unenhanced data transmission in a wireless communication network
2	If causes of poor data transmission in a wireless communication network is partly high	And monitoring sensor is partly not effective replace	And Congestion is partly high reduce	And interference is partly high reduce	And SNR is partly low increase	And throughput is partly low increase	Then result is unenhanced data transmission in a wireless communication network

	reduce						
3	If causes of poor data transmission in a wireless communication network is low maintain	And monitoring sensor is effective maintain	And Congestion is low maintain	And interference is low maintain	And SNR is high maintain	And throughput is high maintain	Then result is enhanced data transmission in a wireless communication network

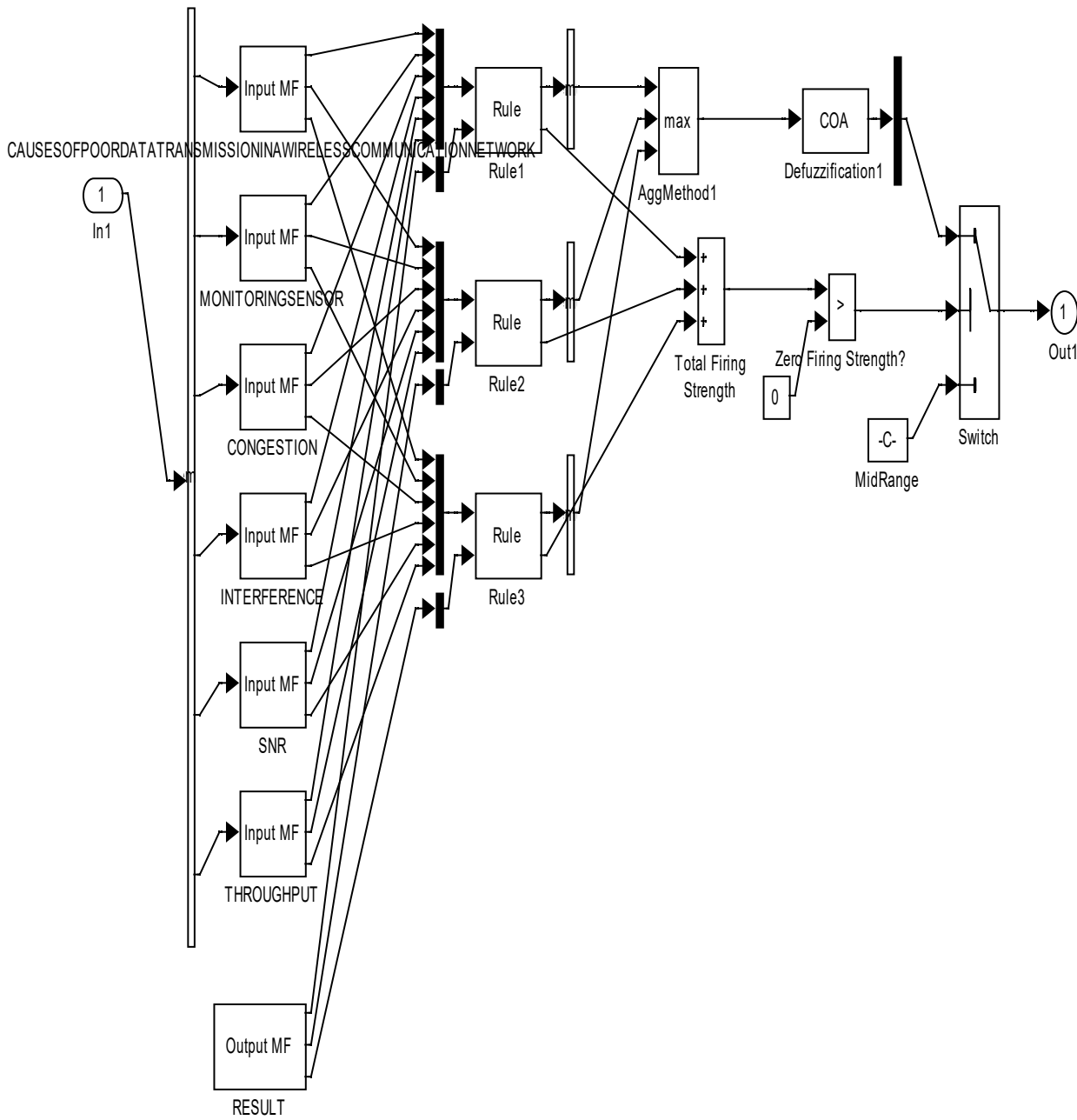

Fig 4 the operational mechanism of developed smart city fuzzy inference system that will minimize the causes of poor data transmission in a wireless communication network

To design a smart city SIMULINK model

Fig 5 designed smart city SIMULINK model

To develop an algorithm that will implement the process

1. Characterize and establish the causes of poor data transmission in a wireless communication network
2. Identify Low Signal Strength
3. Identify High Interference

4. Identify High Noise Level
5. Identify Bandwidth Limitations
6. Identify Excessive Network Latency
7. Identify Packet Loss
8. Identify Jitter (Variation in Packet Arrival Time)
9. Identify Obstructions (Physical Barriers)
10. Identify Overloaded Access Points / Network Congestion
11. Identify Outdated or Incompatible Devices
12. Identify Multipath Fading
13. Identify Improper Antenna Configuration
14. Design a conventional SIMULINK model for data transmission in a wireless communication network and integrate 2 through 13
15. Develop a smart city rule base that will minimize the causes of poor data transmission in a wireless communication network
16. design a smart city SIMULINK model
17. Integrate 15 and 16
18. Integrate 17 into 14
19. Did the causes of poor data transmission in a wireless communication network minimize when 17 was integrated into 14?
20. IF NO go to 18
21. IF YES go 22
22. Enhanced data transmission in a wireless communication network
23. Stop
24. End

To design a SIMULINK model for enhancing data transmission in a wireless communication network using fuzzy based smart city technique

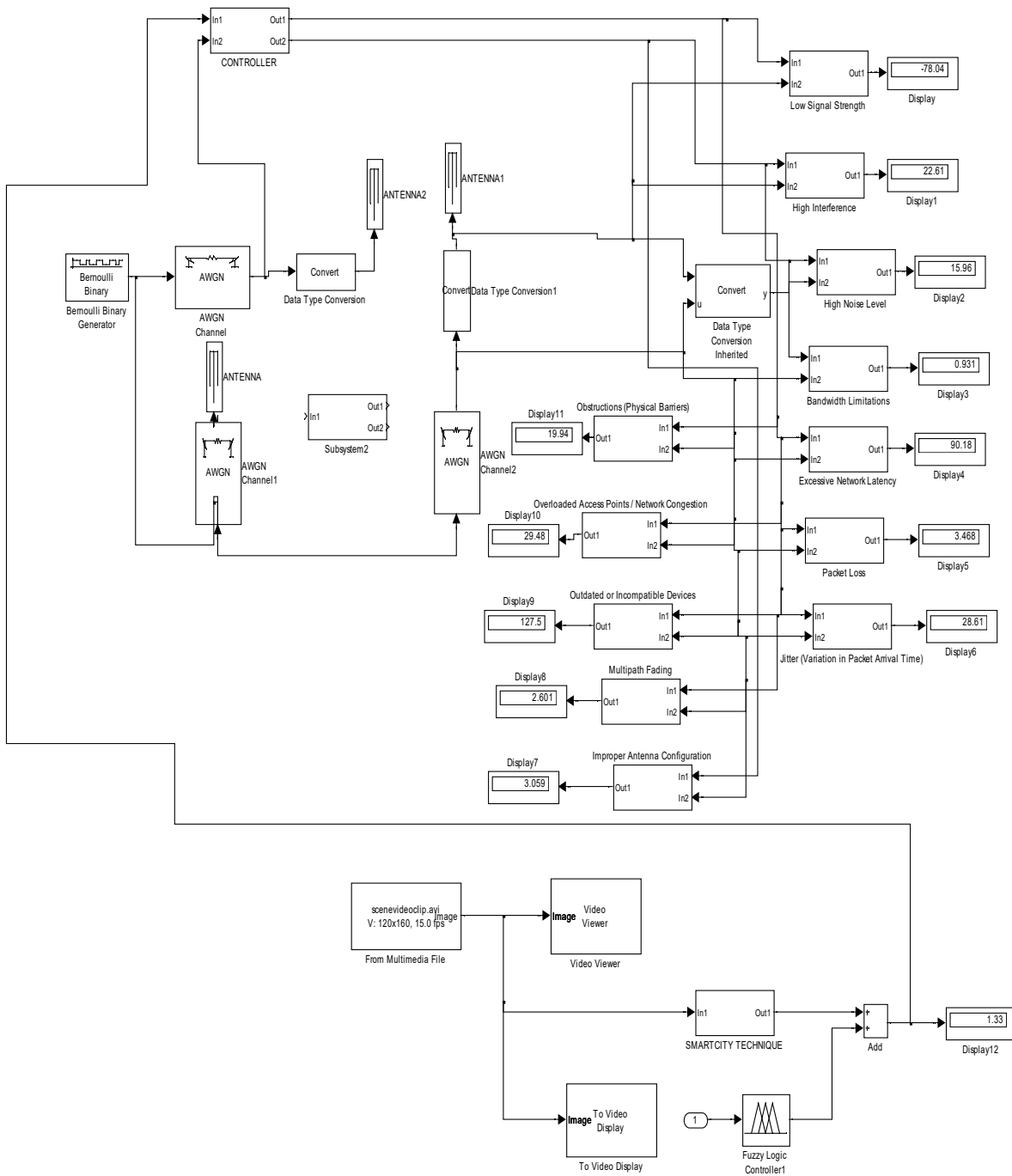

Fig 7 designed SIMULINK model for enhancing data transmission in a wireless communication network using fuzzy based smart city technique

The results obtained were as shown in figures 8 and 9

It validates and justifies the percentage enhancement in the minimization of causes of poor data transmission in a wireless communication network with and without FUZZY based smart city technique

To find percentage improvement in the bandwidth that caused poor data transmission in a wireless communication network with FUZZY based smart city technique

Conventional bandwidth =0.7 Mbps

FUZZY based smart city technique bandwidth=1 Mbps

%improvement in the bandwidth that caused poor data transmission in a wireless communication network with FUZZY based smart city technique=

$$\frac{\text{FUZZY based smart city technique bandwidth} - \text{Conventional bandwidth} \times 100\%}{\text{Conventional bandwidth}}$$

$$\frac{1 \text{ Mbps} - 0.7 \text{ Mbps}}{0.7 \text{ Mbps}} \times 100\%$$

%improvement in the bandwidth that caused poor data transmission in a wireless communication network with FUZZY based smart city technique=

$$\frac{1 \text{ Mbps} - 0.7 \text{ Mbps}}{0.7 \text{ Mbps}} \times 100\% = 42.9\%$$

%improvement in the bandwidth that caused poor data transmission in a wireless communication network with FUZZY based smart city technique=42.9%

To find percentage improvement in the multipath fading that caused poor data transmission in a wireless communication network with FUZZY based smart city technique

Conventional multipath fading =1.3 μs

FUZZY based smart city technique multipath fading =1 μs

%improvement in the multipath fading that caused poor data transmission in a wireless communication network with FUZZY based smart city technique=

$$\frac{\text{Conventional multipath fading} - \text{FUZZY based smart city technique multipath fading} \times 100\%}{\text{Conventional multipath fading}}$$

$$\frac{1.3 \mu\text{s} - 1 \mu\text{s}}{1.3 \mu\text{s}} \times 100\%$$

%improvement in the multipath fading that caused poor data transmission in a wireless communication network with FUZZY based smart city technique=

$$\frac{1.3 \mu\text{s} - 1 \mu\text{s}}{1.3 \mu\text{s}} \times 100\% = 30\%$$

%improvement in the multipath fading that caused poor data transmission in a wireless communication network with FUZZY based smart city technique=30%

3.0 Results and discussion

Table 2 comparison of conventional and FUZZY based smart city technique bandwidth that caused poor data transmission in a wireless communication network

Time(days)	Conventional bandwidth that caused poor data transmission in a wireless communication network(Mbps)	FUZZY based smart city technique bandwidth that caused poor data transmission in a wireless communication network(Mbps)
1	0.7	1
2	0.7	1
3	0.7	1
4	0.7	1
10	0.7	1

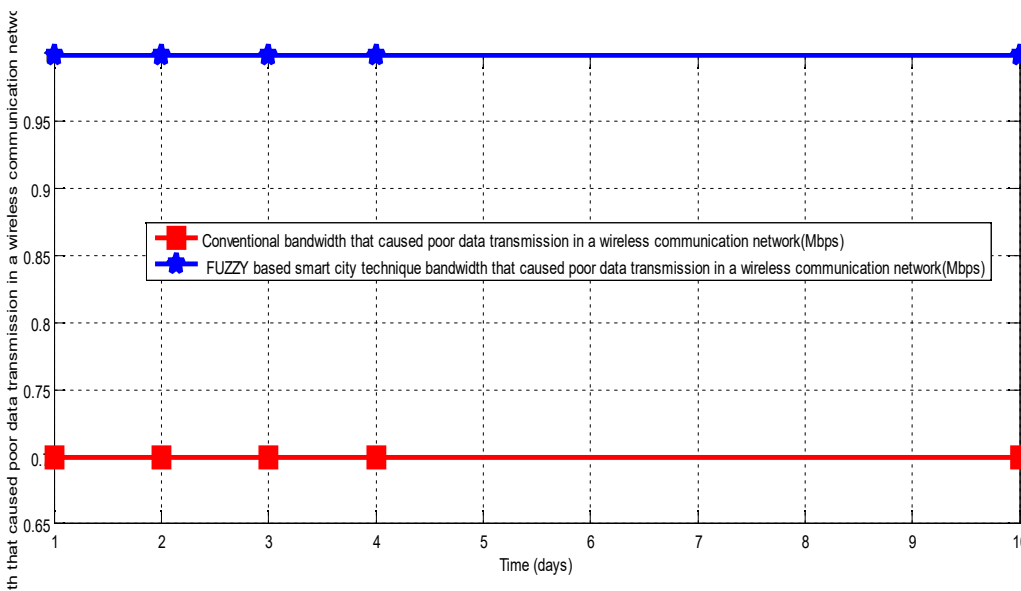

Fig 8 comparison of conventional and FUZZY based smart city technique bandwidth that caused poor data transmission in a wireless communication network

The conventional bandwidth that caused poor data transmission in a wireless communication network was 0.7 Mbps. On the other hand, when FUZZY based smart city technique was integrated into the system, it instantly increased to 1 Mbps.

Table 3 comparison of conventional and FUZZY based smart city technique multipath fading that caused poor data transmission in a wireless communication network

Time(days)	Conventional multipath fading that caused poor data transmission in a wireless communication network(μ s)	FUZZY based smart city technique multipath fading that caused poor data transmission in a wireless communication network(μ s)
1	1.3	1
2	1.3	1
3	1.3	1
4	1.3	1
10	1.3	1

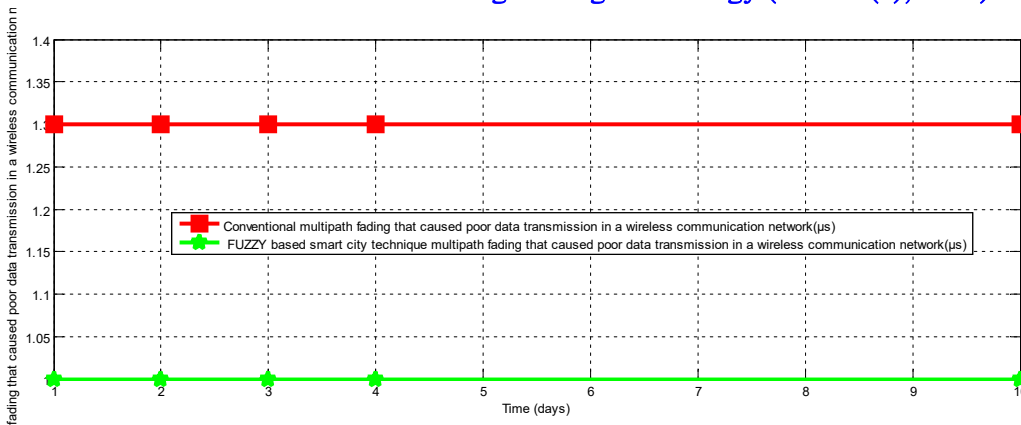

Fig 9 comparison of conventional and FUZZY based smart city technique multipath fading that caused poor data transmission in a wireless communication network

The conventional multipath fading that caused poor data transmission in a wireless communication network was $1.3 \mu\text{s}$. Meanwhile, when FUZZY based smart city technique was imbibed into the system, it simultaneously reduced to $1 \mu\text{s}$. Finally, with these results obtained, it definitely meant that the percentage enhancement in the data transmission in a wireless communication network when FUZZY based smart city technique was incorporated in the system was 30%

4.0 Conclusion

The implementation of a fuzzy-based Smart City technique for enhancing data transmission in wireless communication networks has proven to be an effective solution to the challenges of modern urban connectivity. Through intelligent control and adaptive decision-making, the fuzzy logic system efficiently manages dynamic network conditions, minimizes packet loss, reduces latency, and optimizes throughput. It achieves this by continuously evaluating key network parameters such as signal strength, interference levels, and user density, and applying rule-based adjustments in real time. This approach not only enhances the quality of service (QoS) but also promotes energy efficiency and network stability—two critical requirements for sustainable Smart City development. Compared to conventional static transmission models, the fuzzy-based method demonstrates superior performance in handling uncertain and nonlinear scenarios typically encountered in urban wireless environments. In conclusion, the fuzzy-based Smart City transmission model offers a scalable, resilient, and intelligent framework for future wireless communication networks, supporting real-time applications and digital services critical to Smart City functionality. Its adaptability and efficiency make it a strong candidate for widespread deployment in the evolution of intelligent urban infrastructure. The results obtained were the conventional bandwidth that caused poor data transmission in a wireless communication network was 0.7 Mbps . On the other hand, when FUZZY based smart city technique was integrated into the system, it instantly increased to 1 Mbps and the conventional multipath fading that caused poor data transmission in a wireless communication network was $1.3 \mu\text{s}$. Meanwhile, when FUZZY based smart city technique was imbibed into the system, it simultaneously reduced to $1 \mu\text{s}$. Finally, with these results obtained, it definitely meant that the percentage enhancement in the data transmission in a wireless communication network when FUZZY based smart city technique was incorporated in the system was 30%

References

- Akyildiz, I. F., Su, W., Sankarasubramaniam, Y., & Cayirci, E. (2006). Wireless sensor networks: A survey. *Computer Networks*, 38(4), 393–422.
- Gubbi, J., Buyya, R., Marusic, S., & Palaniswami, M. (2013). Internet of Things (IoT): A vision, architectural elements, and future directions. *Future Generation Computer Systems*, 29(7), 1645–1660.
- Yadav, A., & Singh, S. (2019). A fuzzy logic-based approach to improve QoS in wireless networks. *International Journal of Wireless & Mobile Networks (IJWMN)*, 11(2), 1–10.
- Zadeh, L. A. (1996). Fuzzy logic = computing with words. *IEEE Transactions on Fuzzy Systems*, 4(2), 103–111.

Zanella, A., Bui, N., Castellani, A., Vangelista, L., & Zorzi, M. (2014). Internet of Things for smart cities. *IEEE Internet of Things Journal*, 1(1), 22–32.